



FORZA[®]
Fijación



Vallcal, s.l.
Suministros Industriales

OFERTA ESPECIAL MORDAZAS 2024

15%
dto

www.forza.es

MORDAZA PERFECT



Mordazas de alta precisión para todo tipo de trabajo: fresado, taladrado e incluso rectificado.

Fabricadas en acero de cementación (F155).

Amarre en mesa ranurada o punto cero bajo demanda.

Puntos Clave

- Mordaza sin guiar ó guiada con portabocas oscilante para adaptarse a las piezas a mecanizar. Facilita el amarre de piezas con geometría irregular.
- Bocas con efecto descendente. Hace que la pieza a trabajar apoye perfectamente en la base o paralela.
- Aprietes intercambiables.
- Husillo hexagonal y agujero para la barra de apriete.
- 2 juegos de bridas incluidos.

Cada mordaza incluye un certificado, con la medición real de las cotas principales en una máquina tridimensional Zeiss.

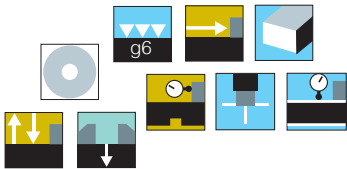

Mordazas NO Guiadas con efecto oscilante

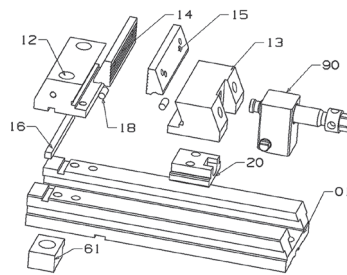
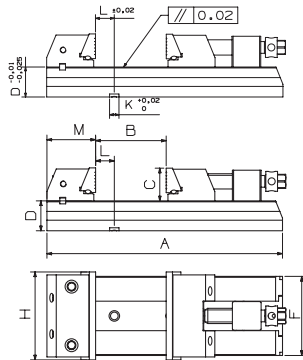
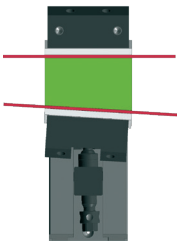

Mordazas Guiadas sin efecto oscilante

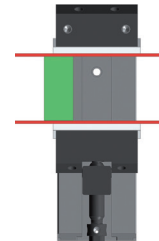

Ref. No Guiada	Precio PVP €/u	OFERTA €/u	A	B	C	D	F	H	L	M				Ref. Guiada	Precio PVP €/u	OFERTA €/u
30/150	1.109,40	942,95	402	200	56	51	135	150	32,2	83	15061	16	B/150	30/150G	1.254,80	1.066,55
30/150L	1.222,10	1.038,80	452	250	56	51	135	150	32,2	83	15061	16	B/150	30/150GL	1.309,70	1.113,25
30/150S	1.367,30	1.162,20	503	300	56	51	135	150	32,2	83	15061	16	B/150	30/150GS	1.429,00	1.214,65
30/200	1.638,10	1.392,40	470	250	66	61	160	200	52,2	92,5	20061	16	B/200	30/200G	1.793,90	1.524,80
30/200L	1.719,70	1.461,75	520	300	66	61	160	200	52,2	92,5	20061	16	B/200	30/200GL	1.924,90	1.636,15
30/200S	2.019,60	1.716,65	570	350	66	61	160	200	52,2	92,5	20061	16	B/200	30/200GS	2.172,90	1.846,95

MORDAZA PARTIDA PARA GRANDES PIEZAS

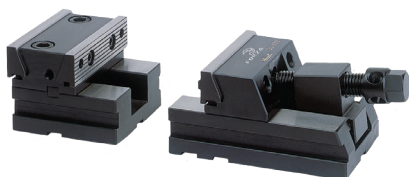

Mordaza partida idónea para el mecanizado de grandes piezas. Fabricadas en acero de cementación F155. 2 juegos de bridas incluidos.



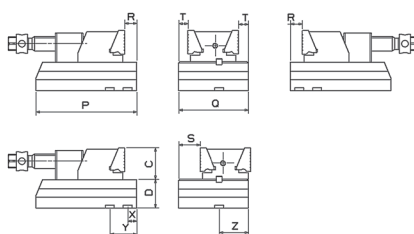

Puntos Clave

- La parte fija es reversible por lo que tenemos dos posiciones de amarre.
- Aprietes intercambiables.
- Bocas con efecto descendente.



Video de mecanizado con mordaza partida.



Ref.	Precio PVP €/u	OFERTA €/u	C	D	P	Q	R	S	T	X	y			
30/100P	929,10	788,75	33,5	37	140	90	50	30	13	17	42	12	1251261	10,0
30/125P	1.001,10	850,95	40	42	150	103	55	35	16	22	50	12	1251261	13,5
30/150P	1.392,60	1.183,70	56	51	180	125	58	40	20	26	58	16	1501261	25,1
30/200P	1.837,50	1.561,90	66	61	190	140	63	44	22	26	58	16	2001261	44,4

MORDAZA AUTOCENTRANTE PARA 5 EJES

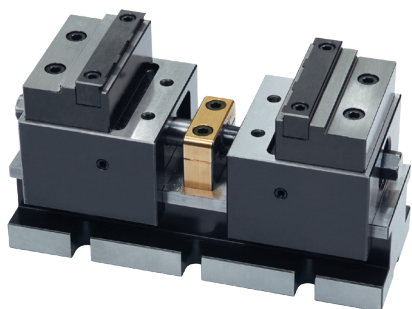

Mordaza versátil de precisión ideal para la automatización en máquinas de 5 ejes.

Si diseño compacto y las características y geometría de los porta bocas y bocas permiten amarrar un amplio abanico de piezas

Fabricadas en acero de cementación F155.





Puntos Clave

- Portabocas reversibles que permiten dos posiciones de amarre diferentes.
- Bocas reversibles, planas por un lado y mordientes por el otro.
- Husillo con rosca trapecoidal.

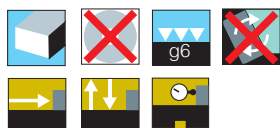
Video



Ref.	Precio PVP €/u	OFERTA €/u	A	Apertura pos.1	Apertura pos.2	C	D	E		
24/75	1.091,80	928,05	192	12-110	60-155	28	90	70	12561	9,0
24/95	1.202,00	1.021,70	250	20-140	80-200	35	105	90	15061	20,0
24/100	1.566,20	1.331,25	394	45-285	105-345	38	105	100	15061	24,0

MORDAZA MULTITASK PARA MESA CONVENCIONAL

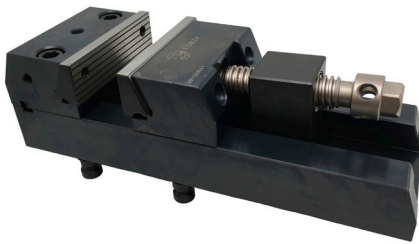

Mordaza universal para todo tipo de operaciones, sobre todo para realizar la segunda operación en máquinas de 5 ejes.
Serie para mesas con ranuras en T. Fuerza de apriete 5 ton.



Puntos Clave

- Muy compacta en apertura máxima. Bocas descendentes.
- Fabricada en acero aleado recubierto con nitruración IONIT OX que aumenta la dureza superficial y le da una gran resistencia a la corrosión, desgaste y fatiga.
- Husillo con un recubrimiento de níquel químico resistente a la corrosión y al desgaste.

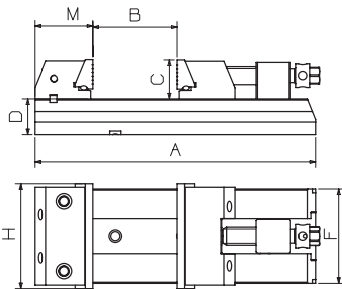
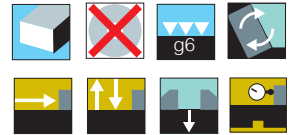

Ref.	Precio PVP €/u	OFERTA €/u	A	B	C	D	M	H	Punto cero	⚖️
30/125A1	905,40	769,60	300	130	40	42	66	125	96	14,1
30/125LA1	966,00	821,10	346	175	40	42	66	125	96	14,6
30/125RA1	978,00	831,30	345	150	52	49	82,5	125	96	18,0
30/125LRA1	1.071,00	910,35	400	200	52	49	82,5	125	96	19,0
30/150CA1	1.280,00	1.088,00	306	100	51	51	83	150	96	23,0
30/150A1	1.390,00	1.181,50	402	200	51	51	83	150	96	27,0

MORDAZA ALTA PARA 5 EJES

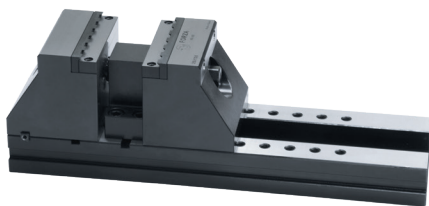

Mordaza idónea para trabajos en 5 ejes donde la pieza a mecanizar se agarre de pocos mm. Fabricada en acero cementado F155.



Puntos Clave

- El portabocas fijo tiene 3 posiciones de amarre diferentes.
- El husillo está completamente escondido y lleva integrado rodamientos que facilitan el apriete.
- Los portabocas son mecanizables para regular la altura del escalón.
- Bocas reversibles: planas por un lado y mordientes por el otro.

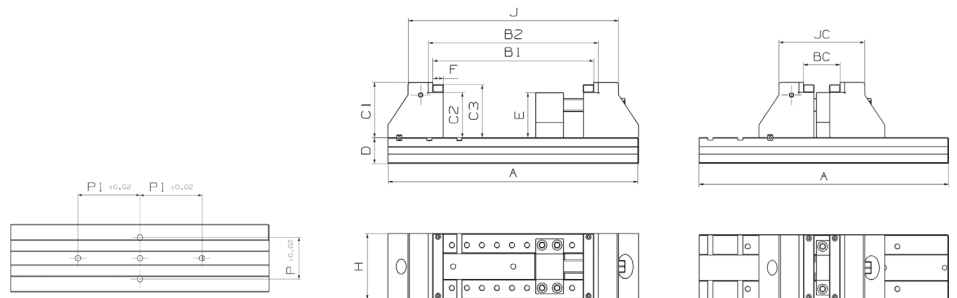
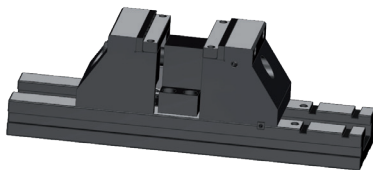

Ref.	Precio PVP €/u	OFERTA €/u	A	BC	B1	B2	C1	C2	C3	D	E	F	H	JC	J	P	P1	⚖️	
25/130	1.874,10	1.593,00	500	74	320	340	110	90	105	51	90	21	130	171	420	80	120	20061	42,0
25/130L	2.095,70	1.781,35	600	74	420	440	110	90	105	51	90	21	130	171	520	80	120	20061	45,0
25/175	2.776,40	2.359,95	590	74	370	400	150	125	140	76	122	25	175	182	480	100	100	20061	89,0
25/175L	2.859,40	2.430,50	710	74	490	520	150	125	140	76	122	25	175	182	600	100	100	20061	98,0